

## LUX ELEMENTS®-RELAX-BW

Montageanleitung

Instructions for assembly

Instruction de montage

Montagehandleiding



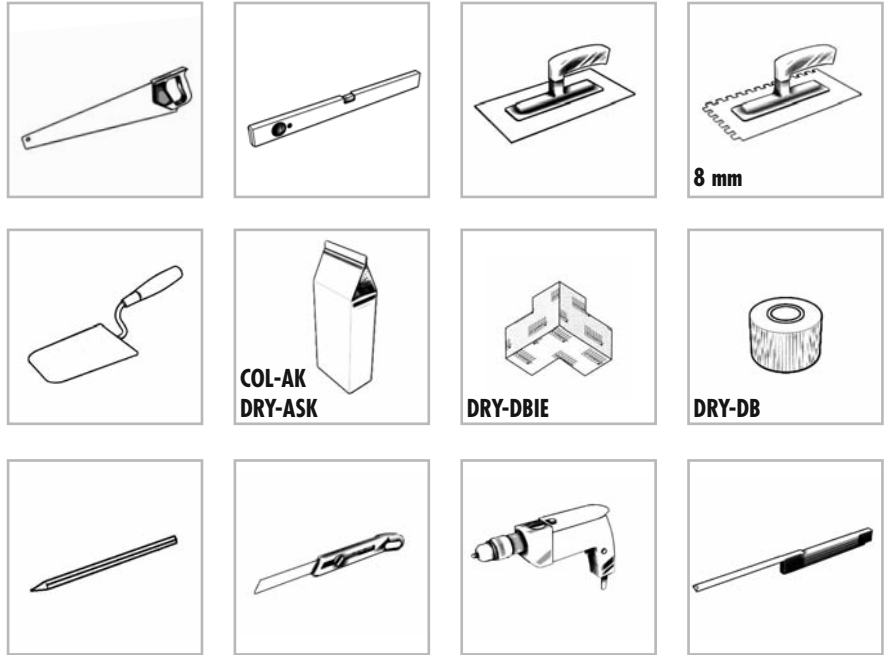
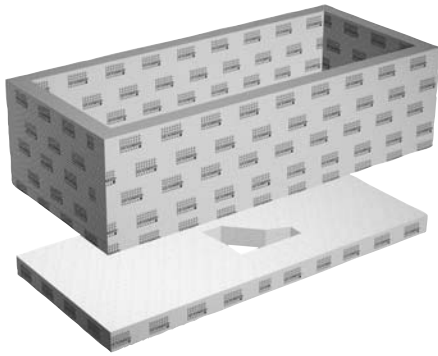

**D Bitte beachten Sie ...**

... unsere Datenblätter, die weitere technische Informationen zur Montage und Verlegung von Belagsmaterialien enthalten. Sie können diese kostenlos von unserer Homepage herunterladen. Generell empfehlen wir bei einer Verlegung von Mosaik von < 5 x 5 cm eine Verklebung und Verfugung mit Reaktionsharz.

**GB Please observe ...**

... our data sheets. These contain further technical information regarding the assembly and installation of cladding materials. You may download them free of charge from our homepage. For mosaic tiles < 5 x 5 cm we generally recommend the use of epoxy for gluing and grouting.

**F Veuillez tenir compte ...**

... de nos fiches techniques qui contiennent de plus amples informations techniques sur le montage et la pose des matériaux de revêtement. Vous pouvez les télécharger gratuitement sur notre site internet. Pour la mise en oeuvre de mosaïque d'un format < 5 x 5 nous conseillons un collage et un jointoyement à l'époxy.

**NL Gelieve op ...**

... onze gegevensbladen te letten. Deze bevatten verdere technische informatie m.b.t. plaatsing van afdekmaterialen. U kan deze kosteloos van onze internetpagina downloaden. Algemeen adviseren wij bij het kleven en het voegen van mosaik < 5 x 5 cm een epoxylijm te gebruiken.

# 1.1

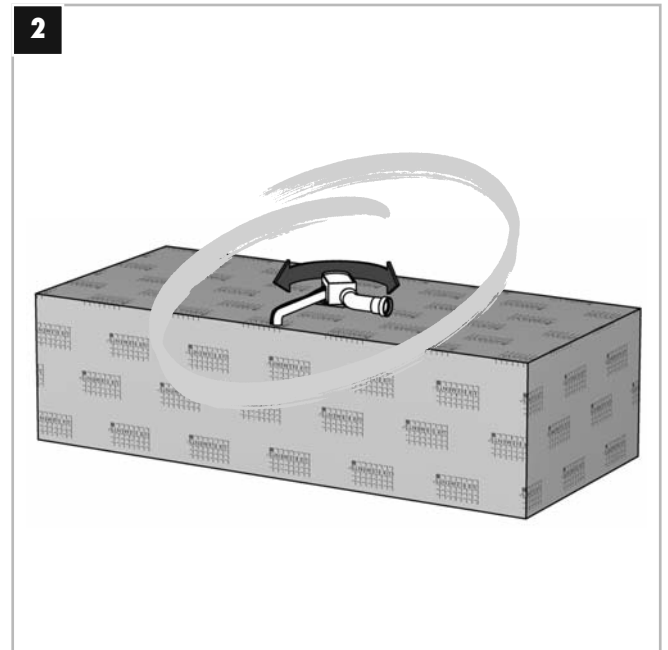
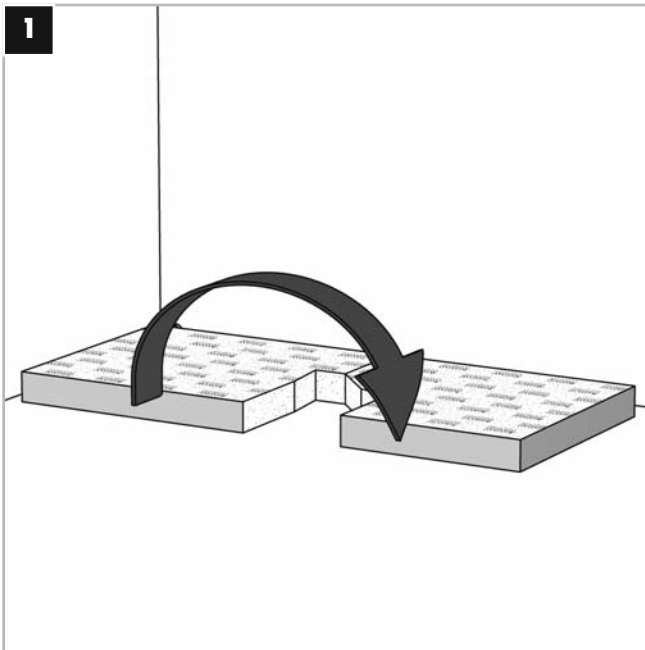
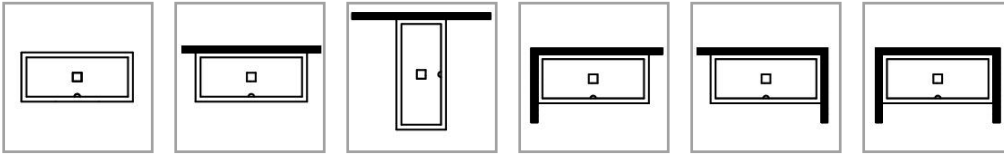

D – Vor dem Kleben der Unterbauelemente bitte einen Trockeneinbau durchführen!  
 GB – Before gluing the substrate elements, please conduct a dry-run.  
 F – Avant de coller l'élément de support, veuillez exécuter un montage à sec !  
 NL – Vooraleer de onderbouwelementen te kleven, gelieve ze droog te monteren!

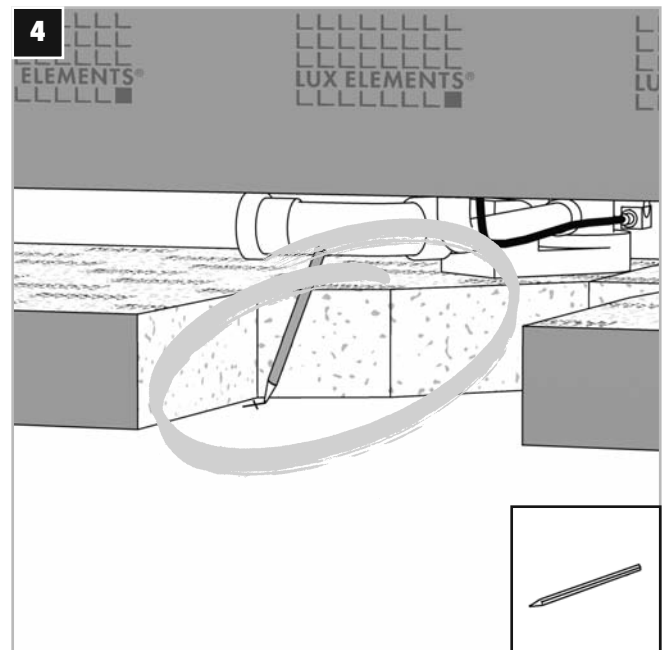
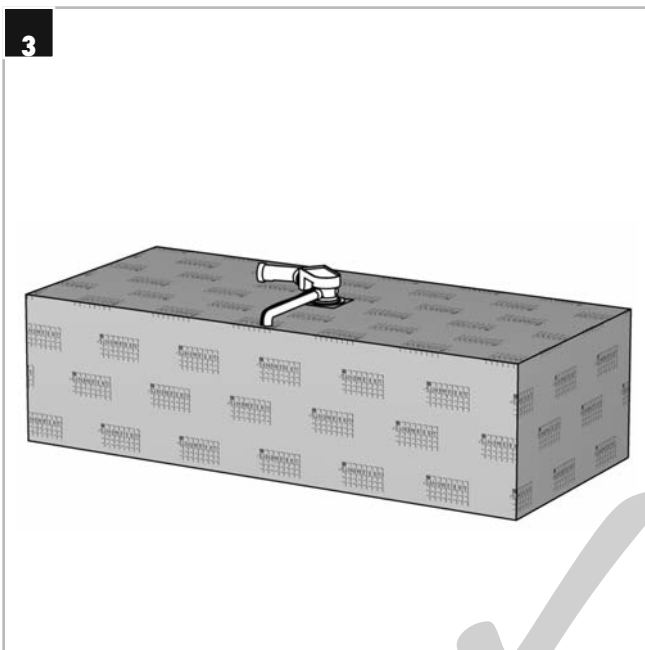

# 1.1

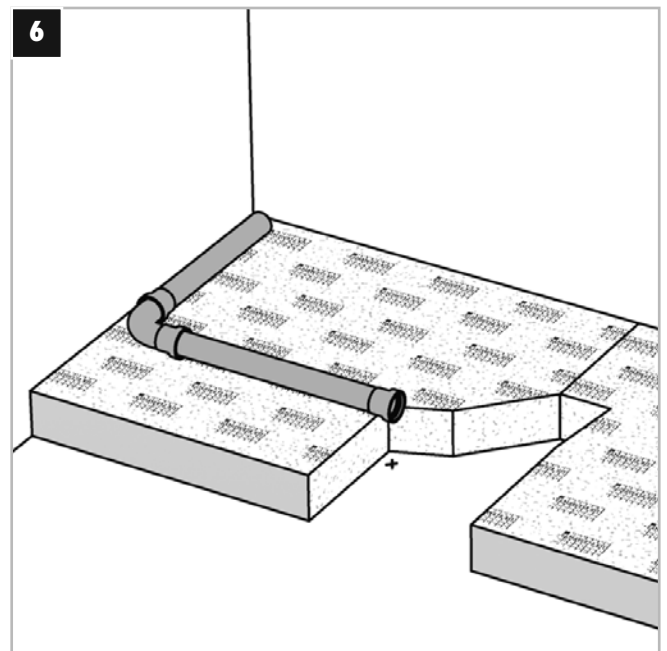
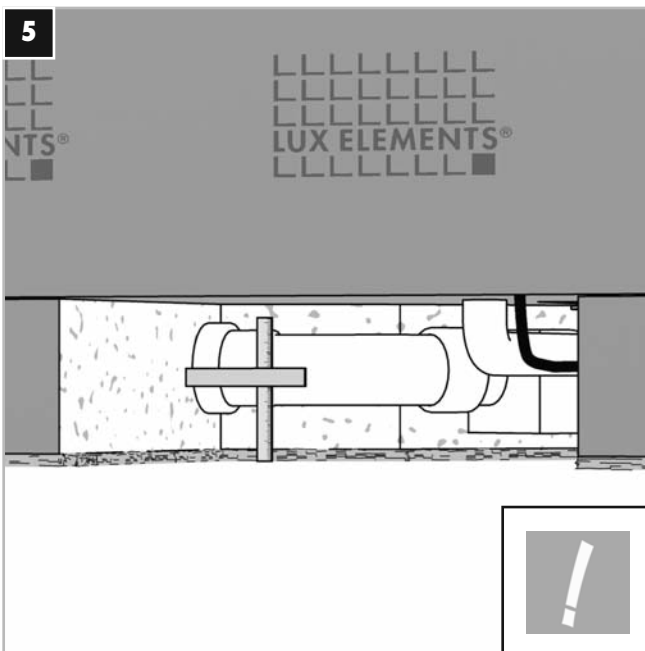

D – Die Höhe des Anschluss-Kanals beachten! Bei Montage auf Kleberbatzen die Batzenhöhe dazu addieren.  
 GB – Consider the height of the connection channel! When assembling on adhesive dots add height of dots as well  
 F – Respecter la hauteur du tuyau de raccordement ! Pour le montage sur plots de colle, rajouter la hauteur des plots.  
 NL – Houd rekening met de hoogte van het aansluitkanaal! Bij montage op hoopjes lijm de hoogte van de lijm erbij tellen.

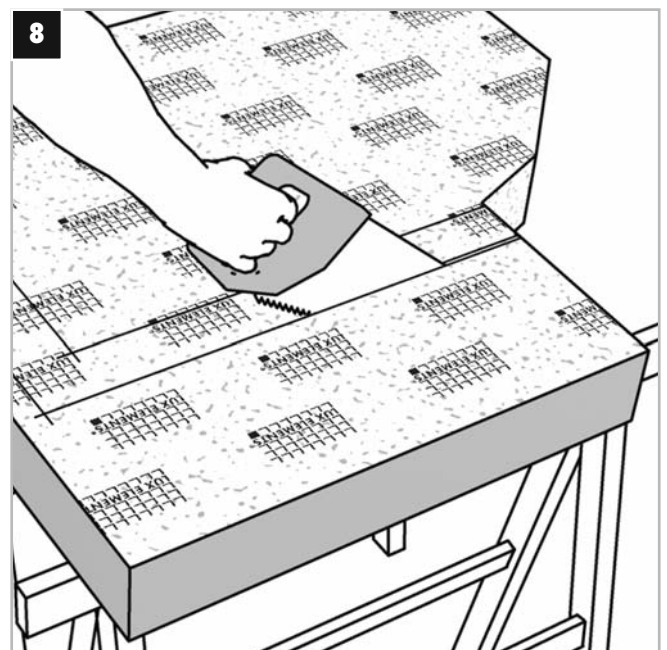
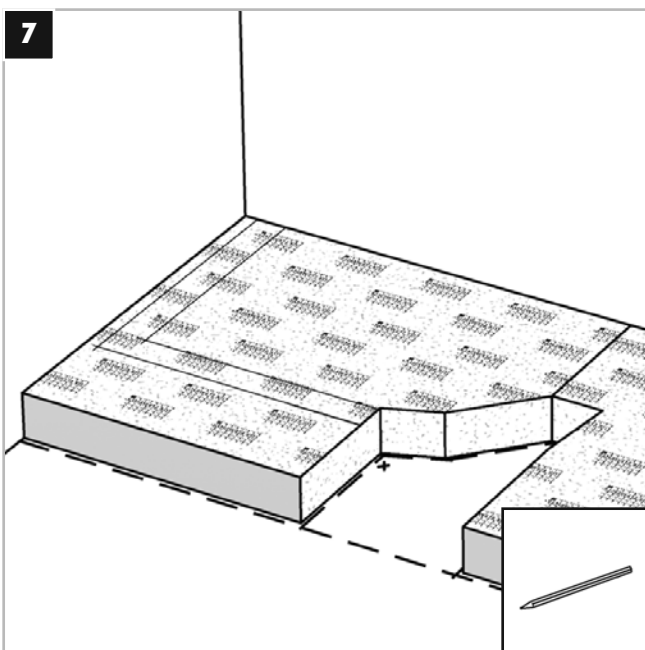

# 1.1

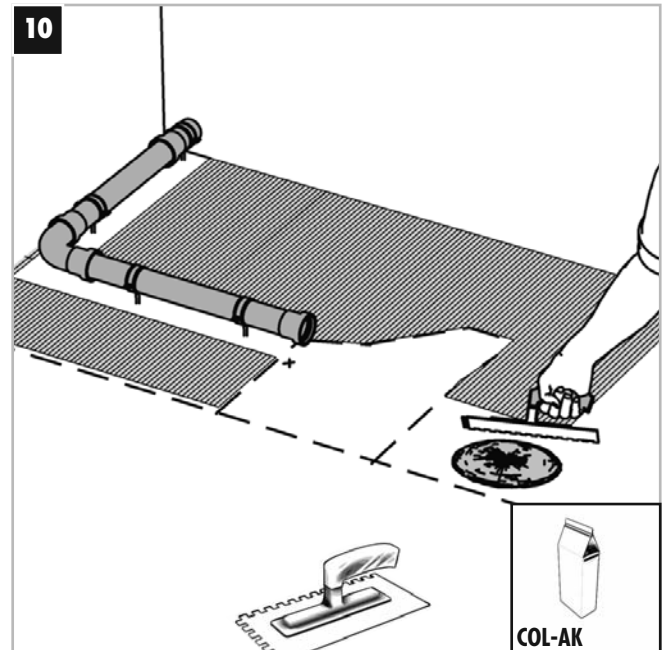
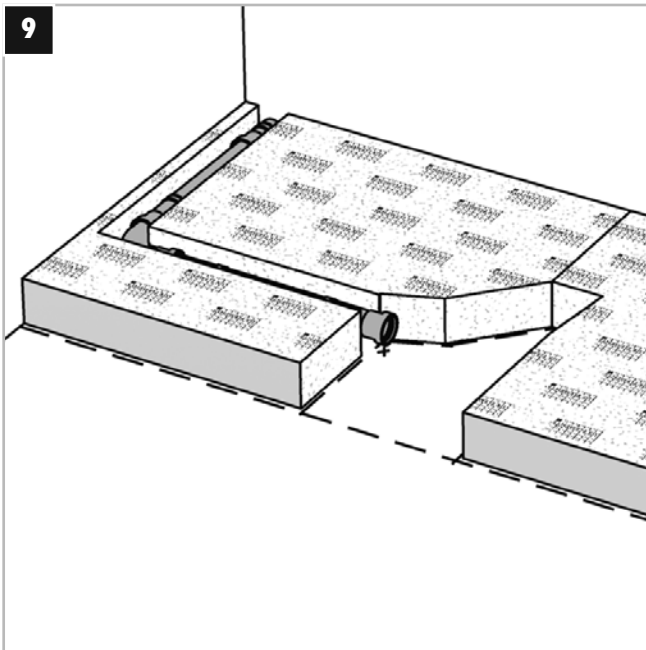

8 mm

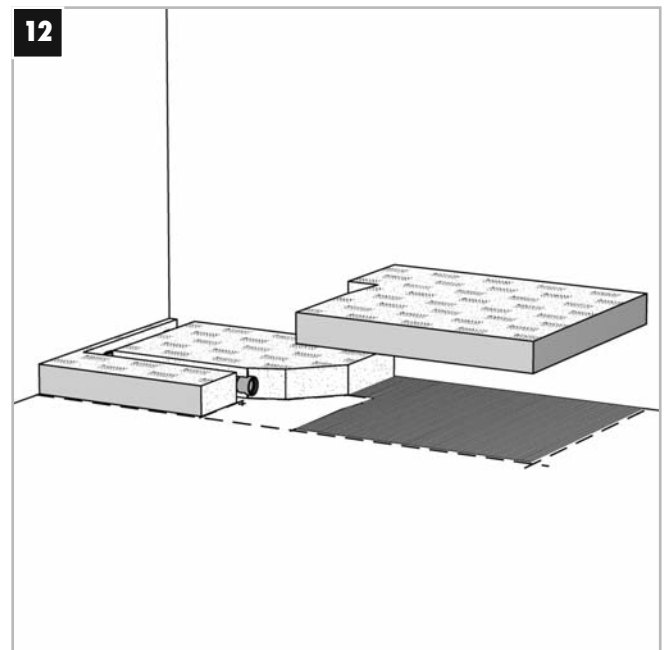
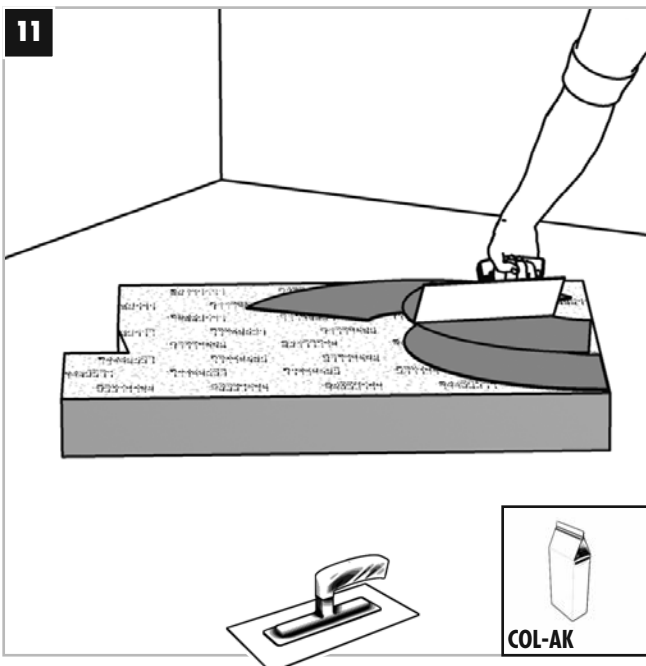

# 1.1

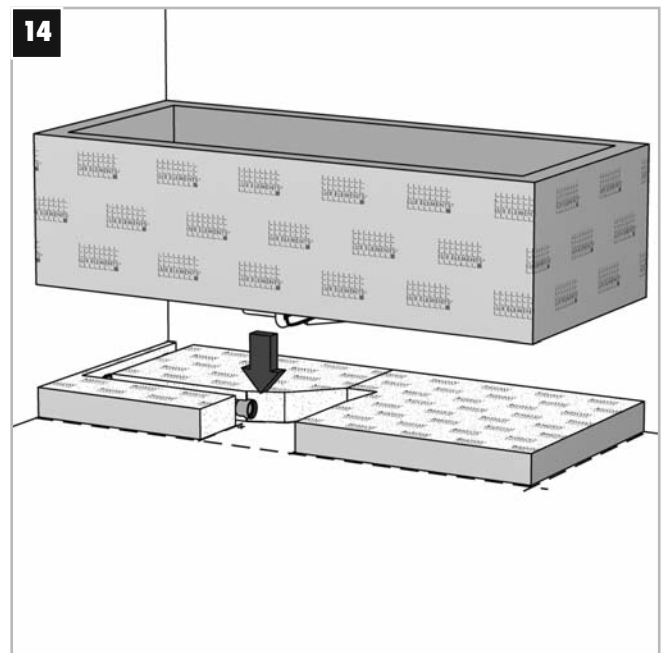
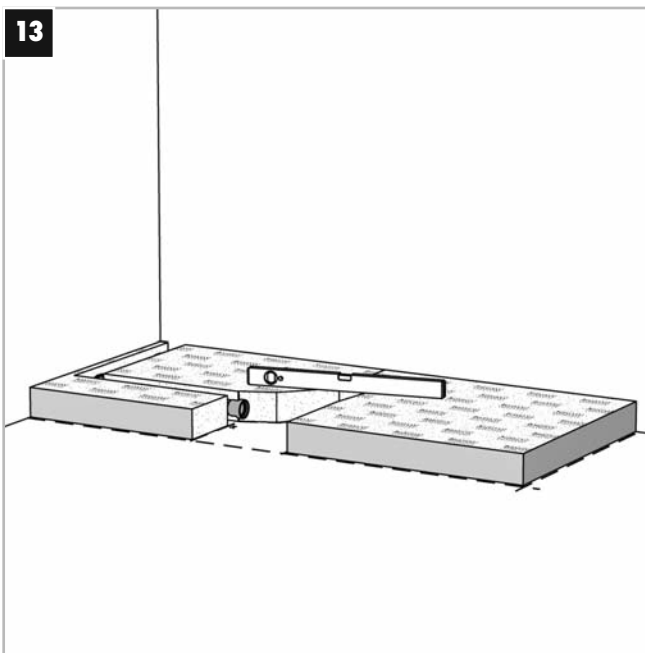

D – Vor dem Verkleben mit den Unterbauelementen bitte einen Trockeneinbau durchführen!  
 GB – Before gluing the substrate elements, please conduct a dry-run.  
 F – Avant de coller sur l'élément de support, veuillez exécuter un montage à sec  
 NL – Vooreleer de kuip aan de onderbouwelementen vast te kleven, gelieve deze droog te monteren!

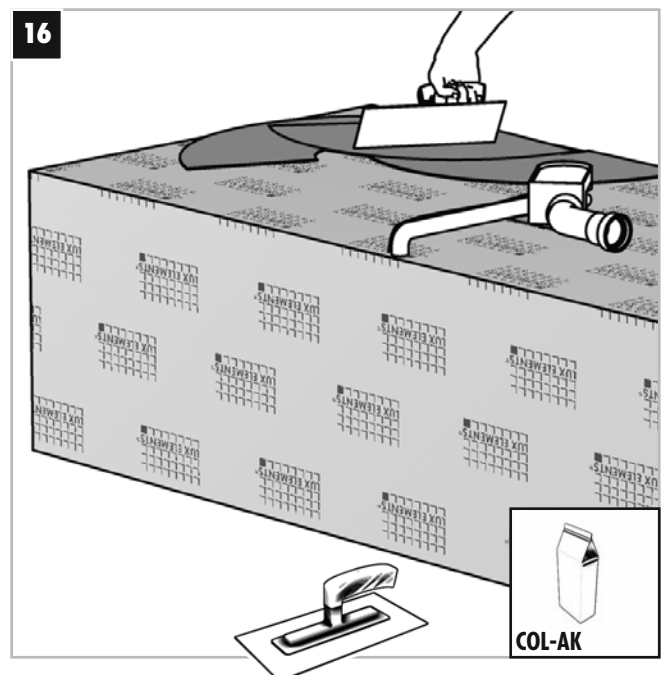
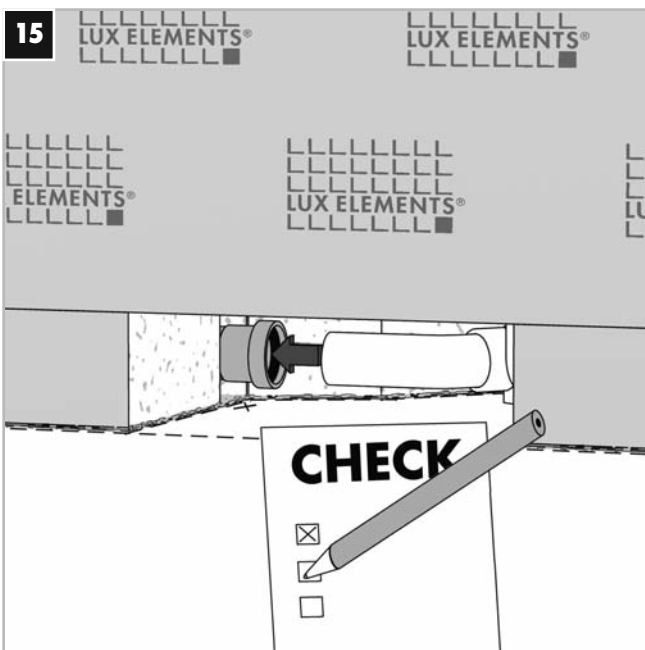

# 1.1

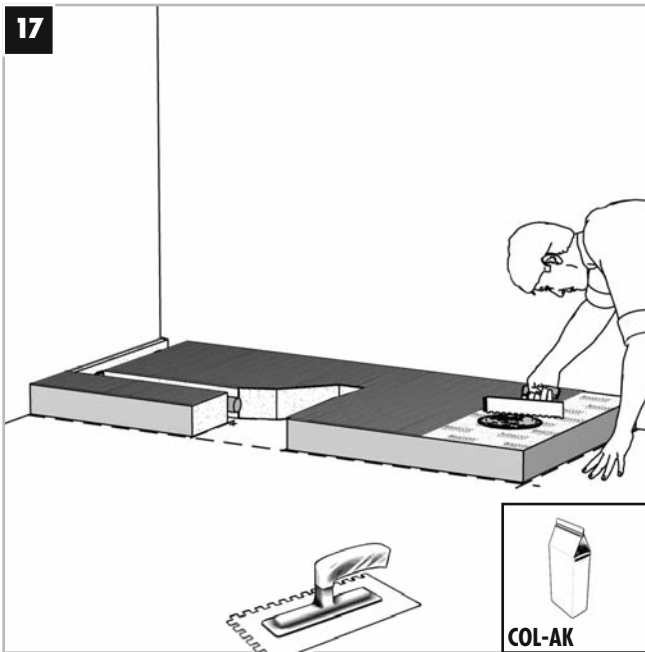

8 mm

COL-AK

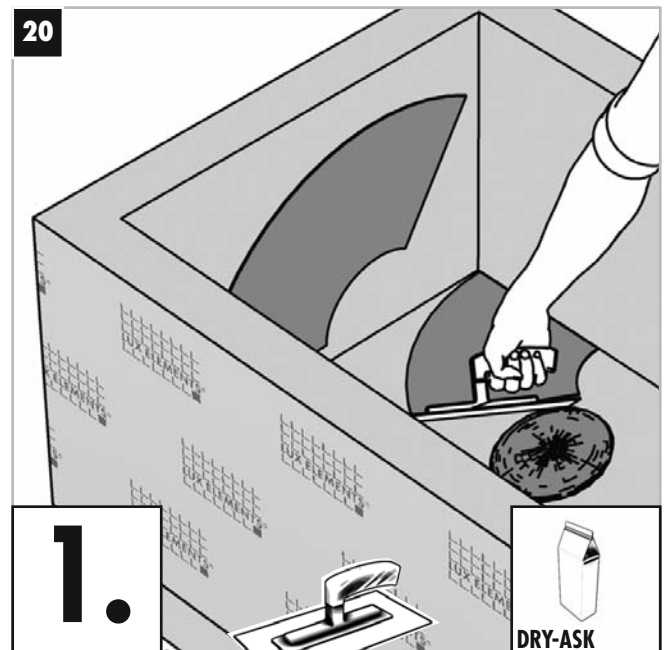
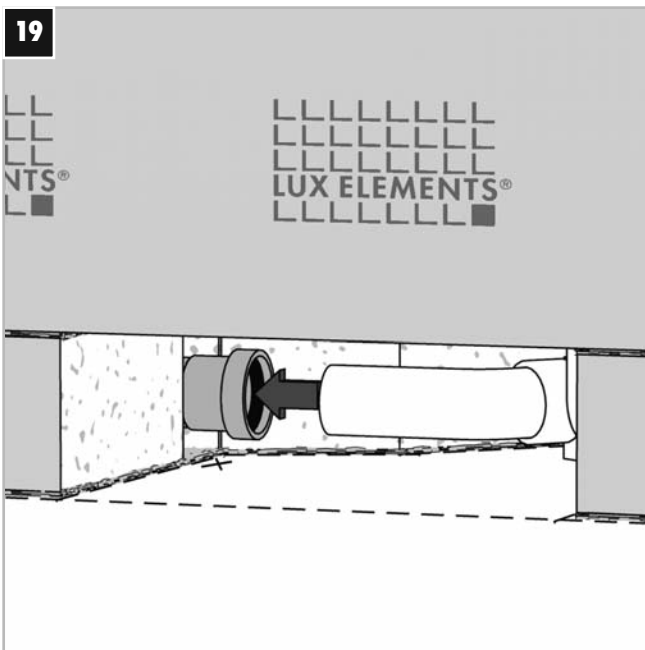
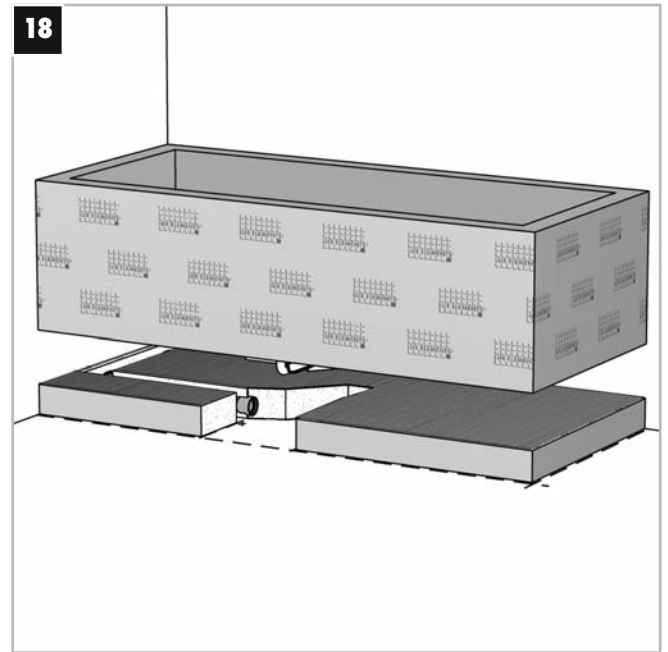

1.

DRY-ASK

# 1.1

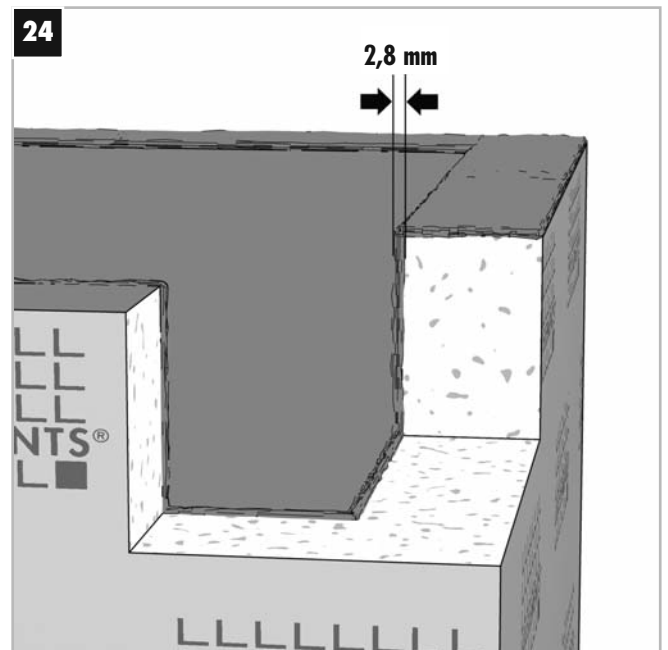
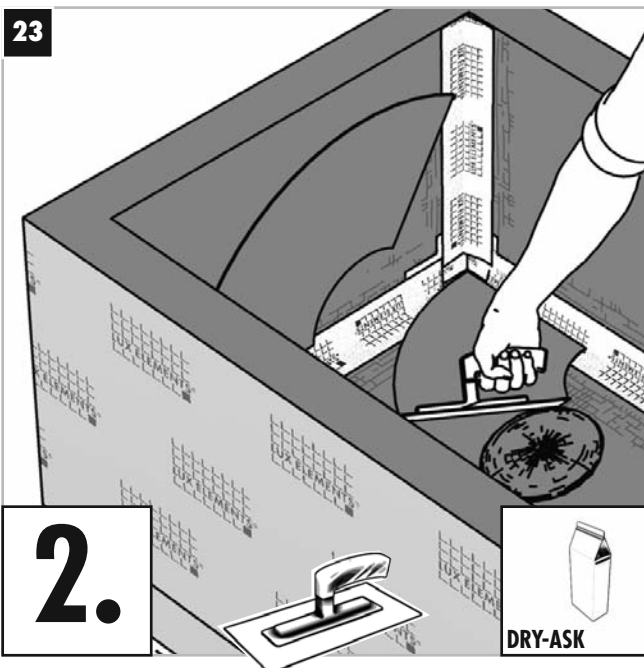
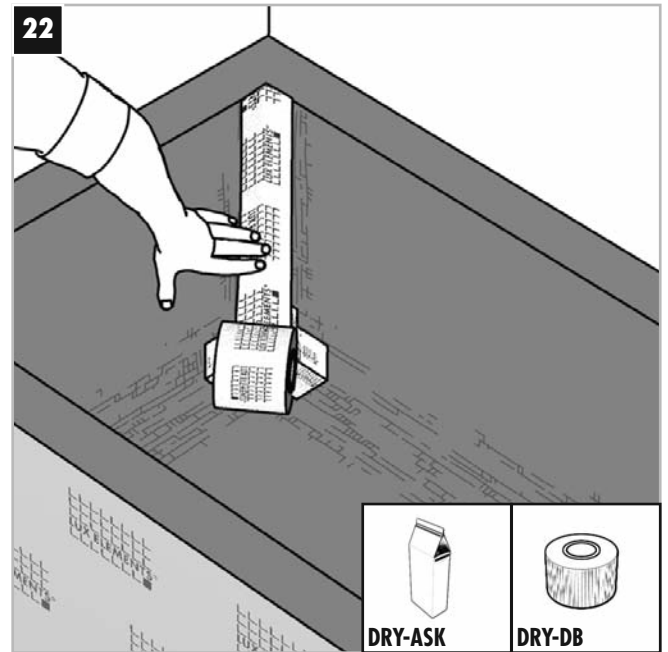
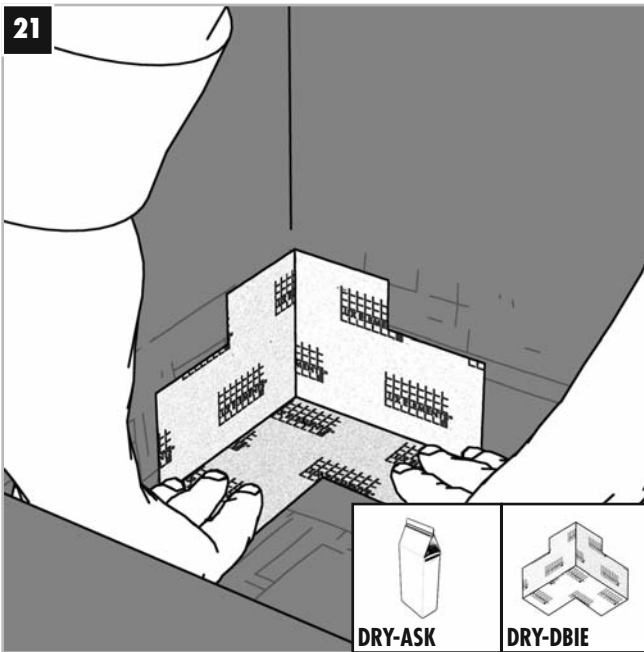

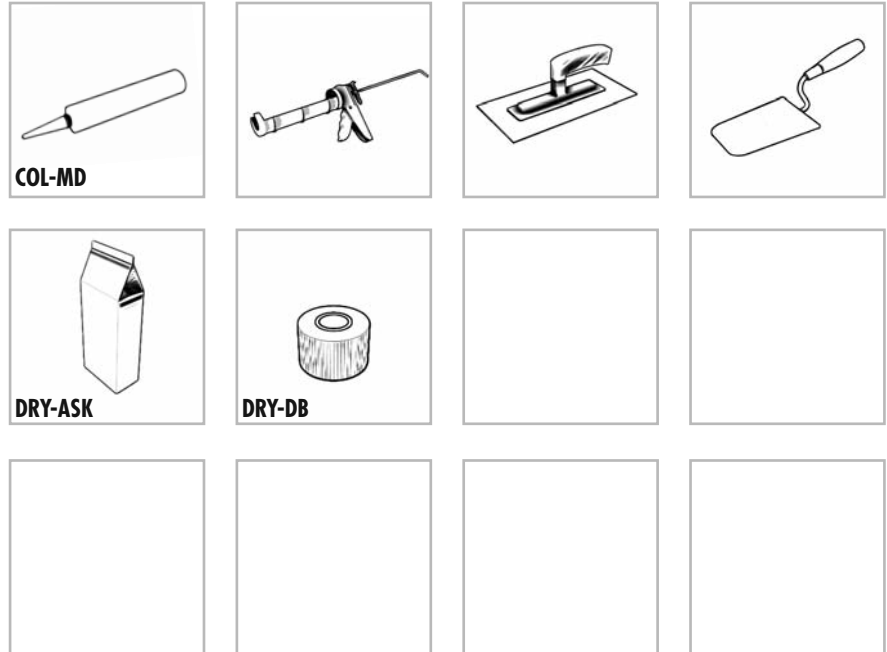
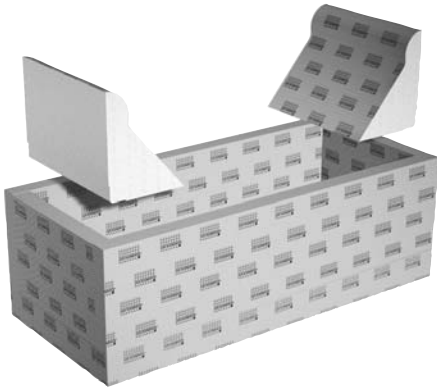

**D Bitte beachten Sie ...**

... unsere Datenblätter, die weitere technische Informationen zur Montage und Verlegung von Belagsmaterialien enthalten. Sie können diese kostenlos von unserer Homepage herunterladen. Generell empfehlen wir bei einer Verlegung von Mosaik von < 5 x 5 cm eine Verklebung und Verfugung mit Reaktionsharz.

**GB Please observe ...**

... our data sheets. These contain further technical information regarding the assembly and installation of cladding materials. You may download them free of charge from our homepage. For mosaic tiles < 5 x 5 cm we generally recommend the use of epoxy for gluing and grouting.

**F Veuillez tenir compte ...**

... de nos fiches techniques qui contiennent de plus amples informations techniques sur le montage et la pose des matériaux de revêtement. Vous pouvez les télécharger gratuitement sur notre site internet. Pour la mise en oeuvre de mosaïque d'un format < 5 x 5 nous conseillons un collage et un jointoyement à l'époxy.

**NL Gelieve op ...**

... onze gegevensbladen te letten. Deze bevatten verdere technische informatie m.b.t. plaatsing van afdekmaterialen. U kan deze kosteloos van onze internetpagina downloaden. Algemeen adviseren wij bij het kleven en het voegen van mosaik < 5 x 5 cm een epoxylijm te gebruiken.

# 1.2

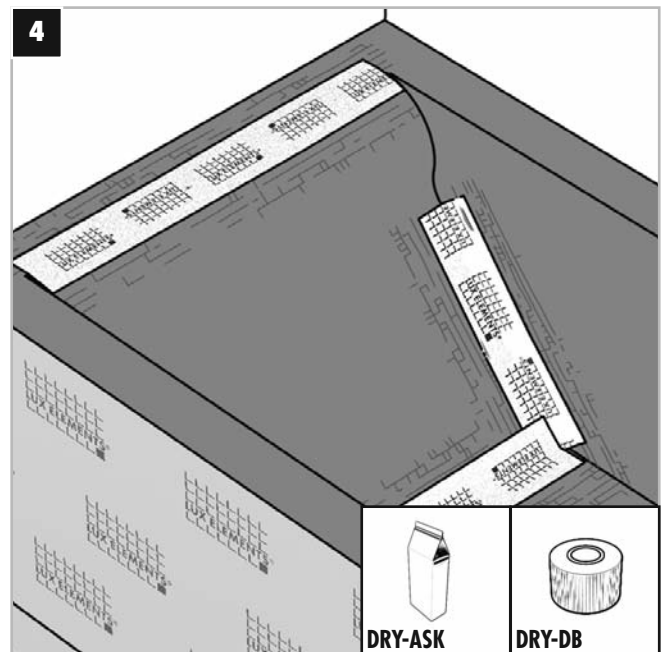
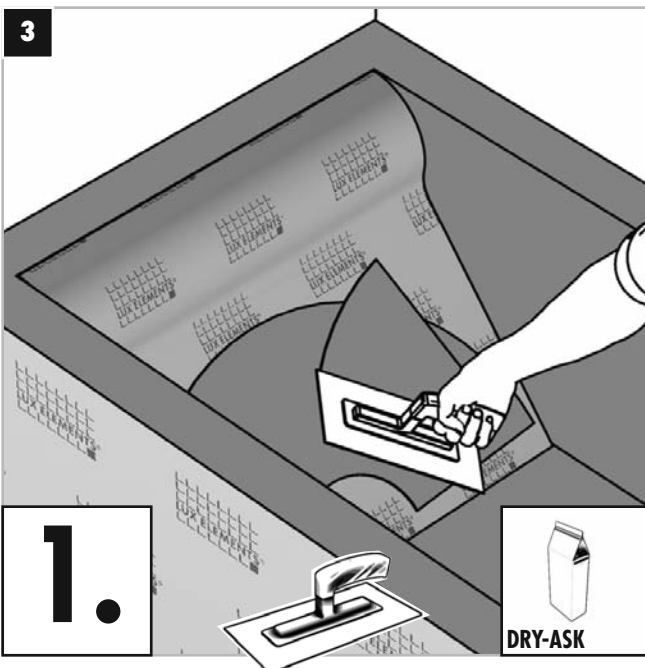
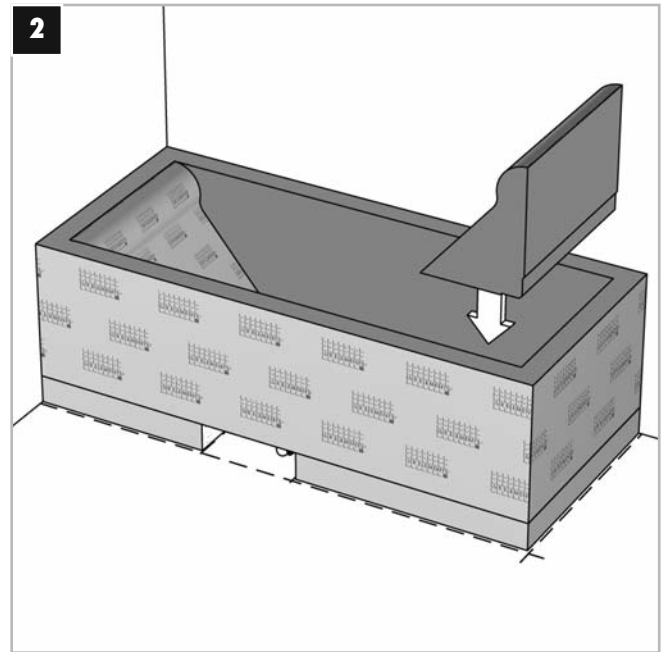
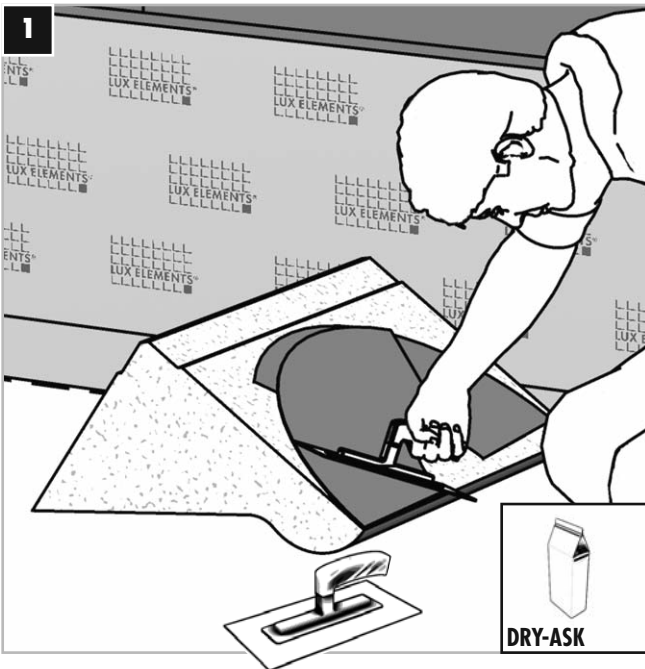

# 1.2

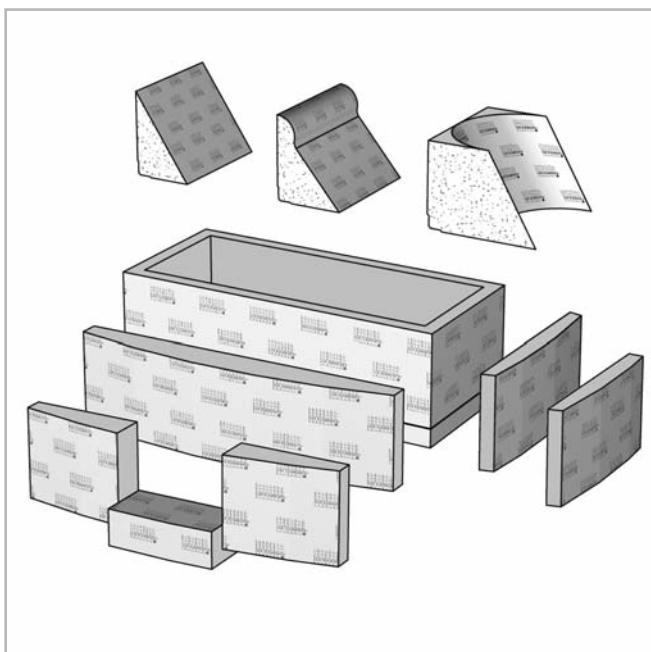
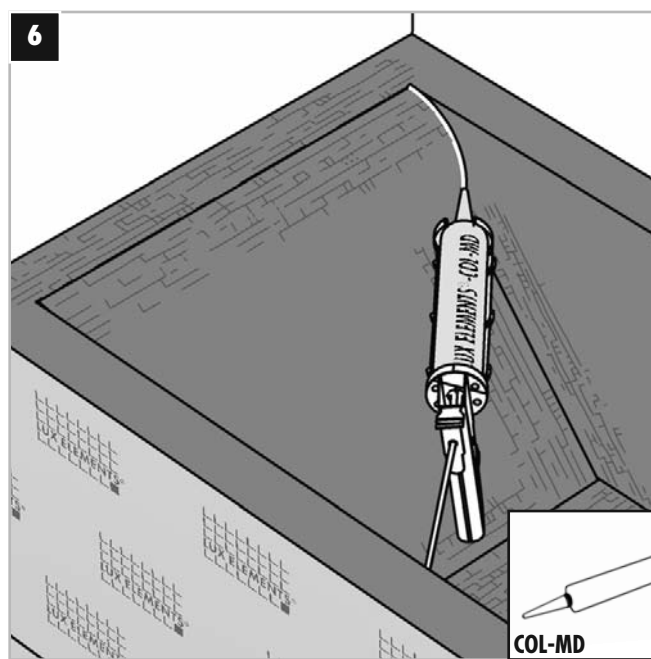
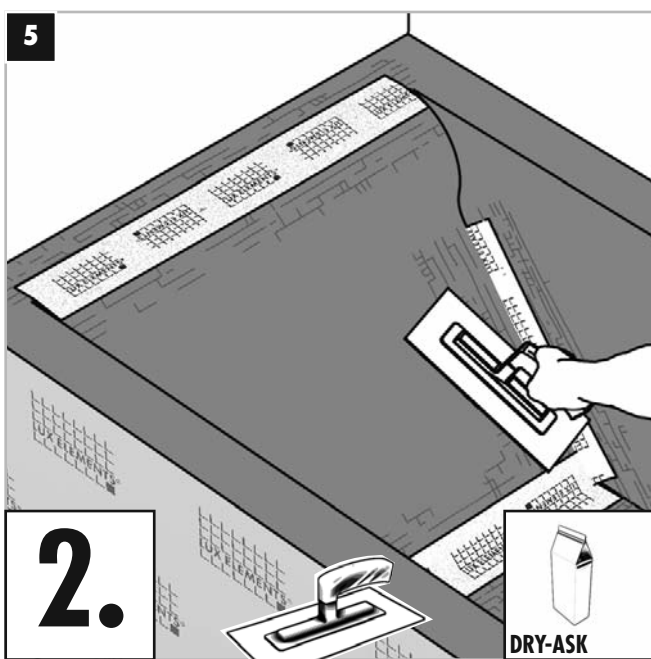

**D Bitte beachten Sie ...**  
 ... die hier am Beispiel 'RELAX-BW EK' gezeigte Systematik gilt für alle Einbauteile, Montage der Anbauteile -> siehe Seite 17

**GB Please observe ...**  
 ... the method shown here, using for example the 'RELAX-BW EK', is valid for all inlay elements; assembly of the attachment elements -> see page 17

**F Veuillez tenir compte ...**  
 ... l'exemple de montage donné ici avec l'élément « RELAX-BW EK » est valable pour tous les éléments -> voir page 17

**NL Gelieve op ...**  
 ... de systematiek die hier aan de hand van het voorbeeld 'RELAX-BW EK' getoond wordt, geldt voor alle montagstukken, Montage van de aanbouwdelen -> zie pagina 17

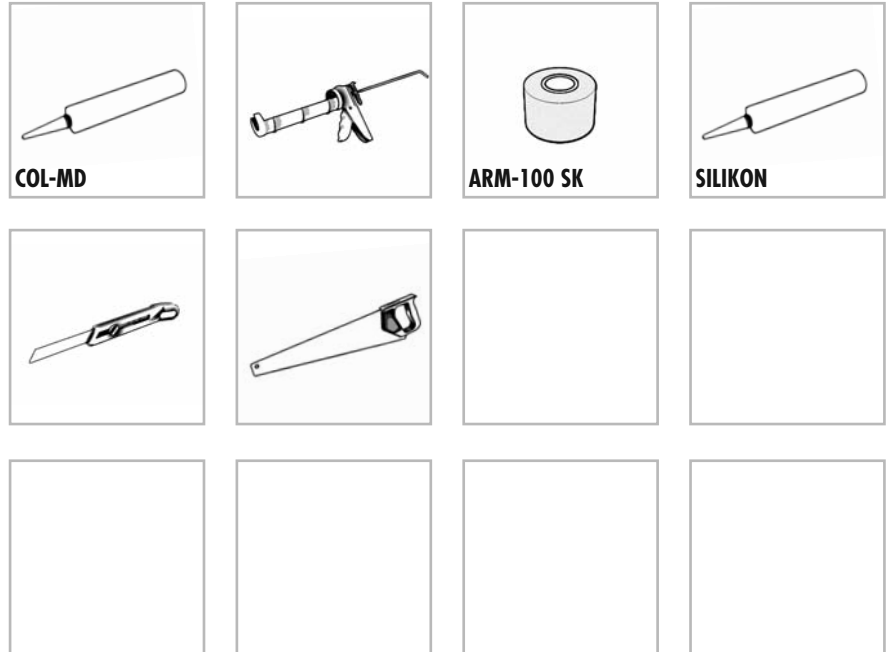
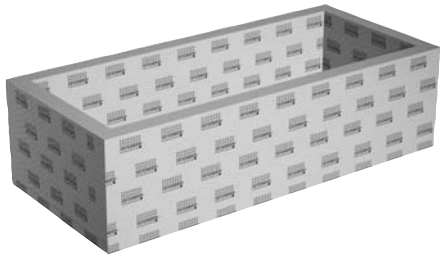

**D Bitte beachten Sie ...**

... auch bei einer bereits werkseitig abgedichteten RELAX-BW muß beim Einbau eine weitere Lage DRY-ASK (siehe Seite 8) aufgetragen werden. Um die Dichtigkeit der gesamten Installation zu überprüfen, muß eine Probefüllung (3 Tage) vorgenommen werden. Diese ist mit dem beigefügten Prüfprotokoll (Seite 14) zu dokumentieren.

**GB Please observe ...**

... even if the RELAX-BW comes with a factory-made sealing another layer of DRY-ASK has to be applied during installation (see page 8). To check the sealing of the whole installation a sample filling has to be carried out (3 days). This is to be documented in the attached Test Report (page 14).

**F Veuillez tenir compte ...**

... Même pour un RELAX-BW déjà scellé en usine, une couche supplémentaire de DRY-ASK doit être appliquée au montage (voir page 8). Pour vérifier l'étanchéité de l'ensemble de l'installation, un remplissage d'essai (3 jours) doit être effectué. Ceci doit être documenté avec le procès verbal d'essai joint (page 14).

**NL Gelieve op ...**

... ook bij een reeds in de fabriek afgedichte RELAX-BW moet bij de montage nog een laag DRY-ASK (zie pagina 8) worden aangebracht. Om de dichtheid van de volledige installatie te controleren, moet er een proefvulling (3 dagen) worden uitgevoerd. Deze moet met het bijgevoegde testprotocol (pagina 14) worden gedocumenteerd.

# 2

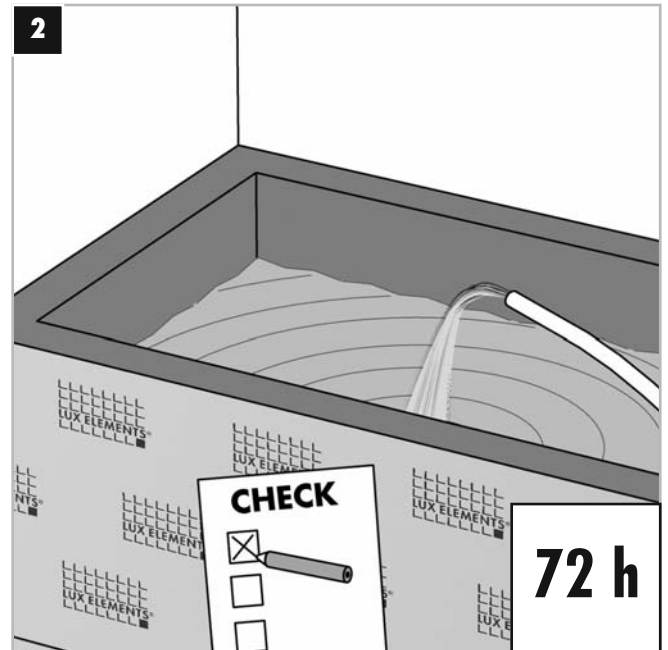
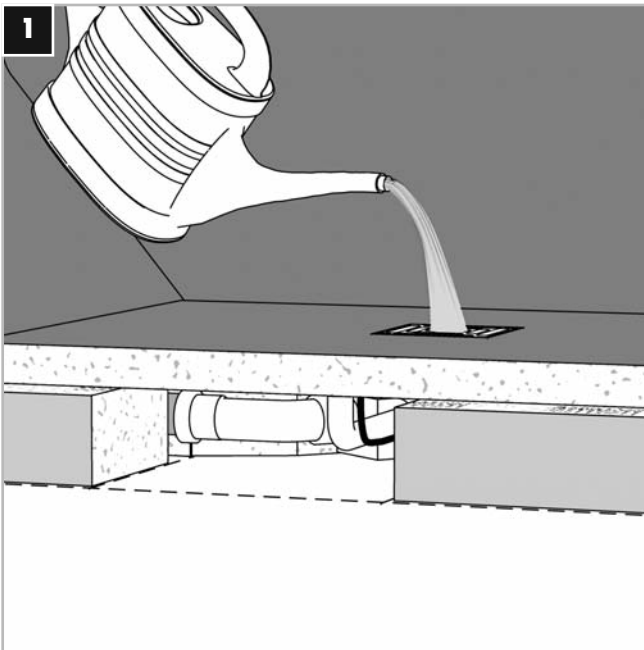

D – Bitte die Hinweise auf Seite 12 beachten!  
 GB – Please follow the notes on page 12!  
 F – Veuillez respecter les conseils de la page 12 !  
 NL – Gelieve de aanwijzingen op pagina 12 op te volgen!

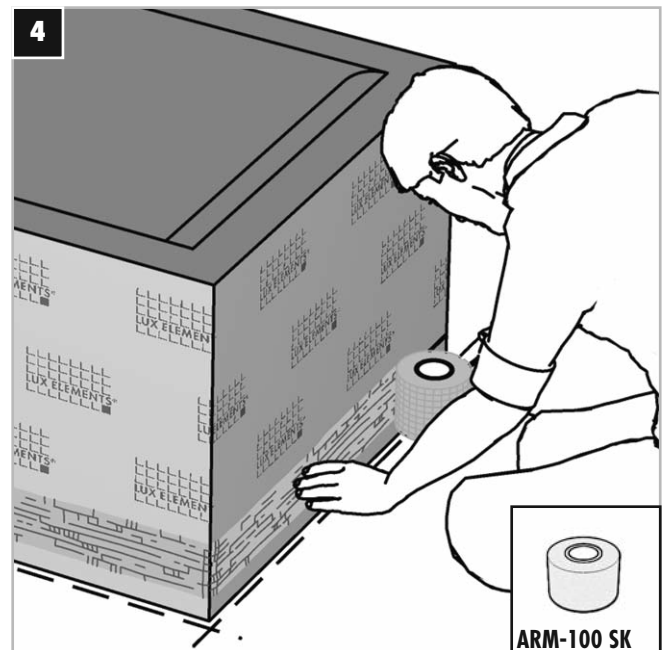
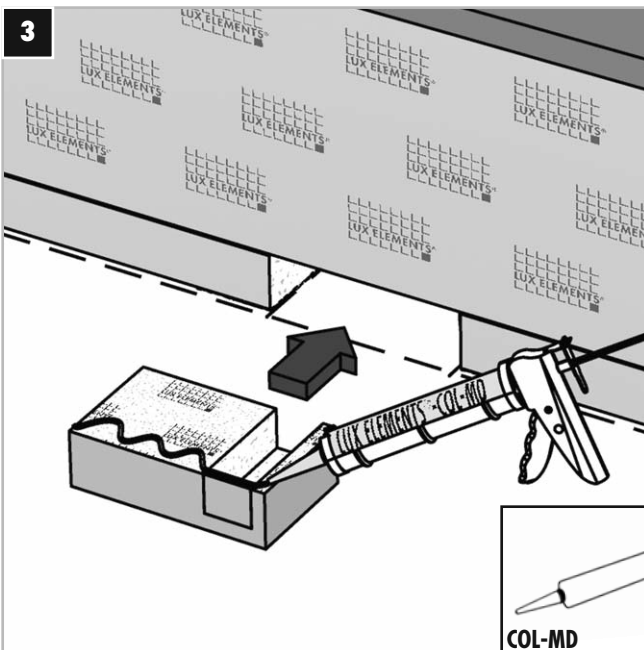

# LUX ELEMENTS®-RELAX-BW

Prüfprotokoll Dichtigkeit

Sealing Test Report

Procès verbal d'essai d'étanchéité

Testprotocol dichtheid

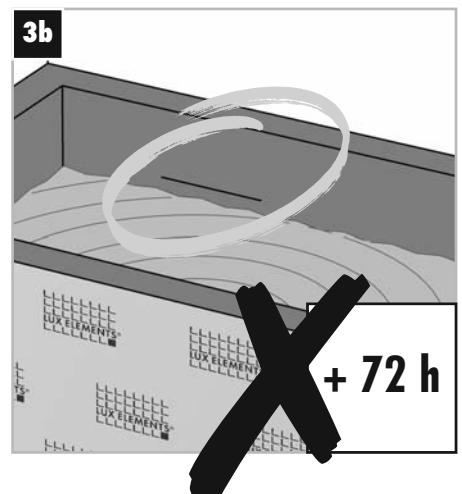
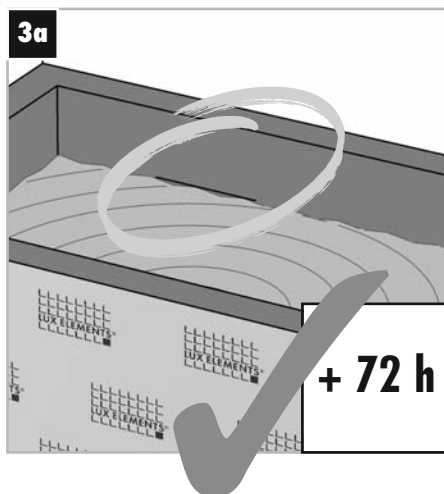
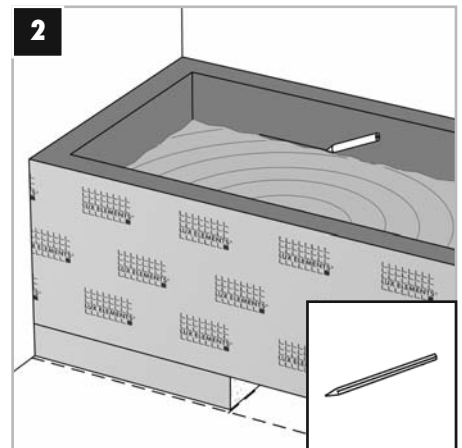
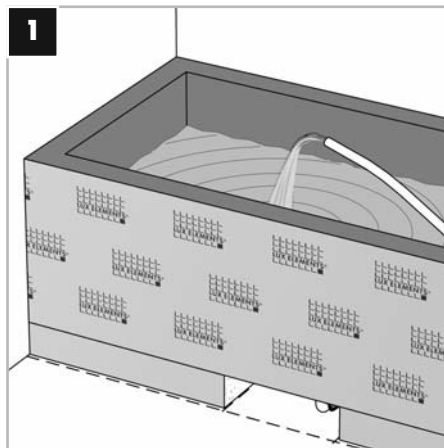

Befüllt am: \_\_\_\_\_  
Filled on · Rempli le · Gevuld op

Überprüft am: \_\_\_\_\_  
Checked on · Vérifié le · Gecontroleerd op

durch: \_\_\_\_\_  
by · par · door

durch: \_\_\_\_\_  
by · par · door

Unterschrift: \_\_\_\_\_  
Signature · Signature · handtekening

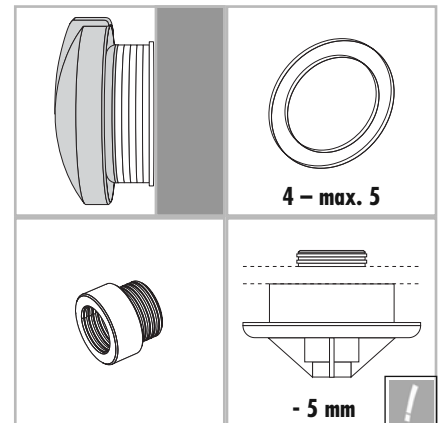
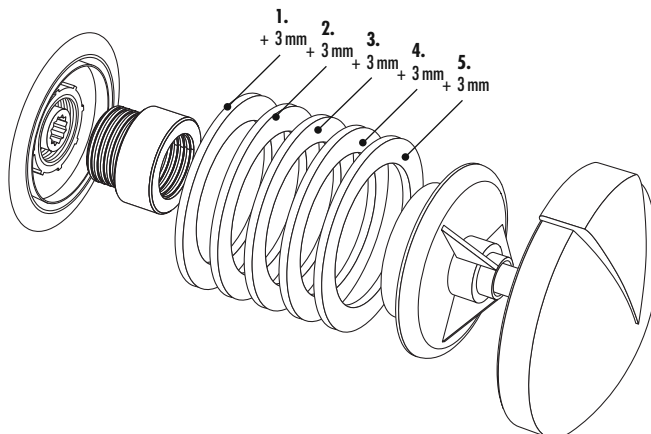
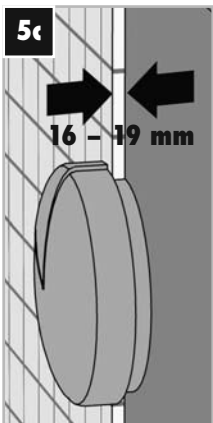
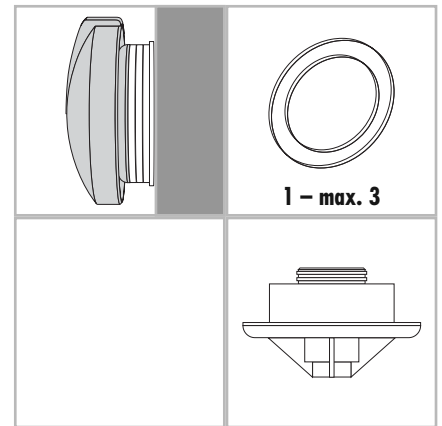
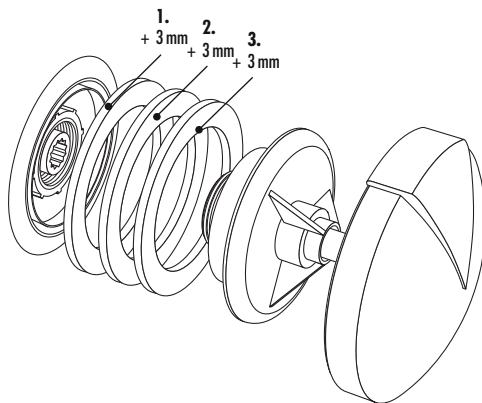
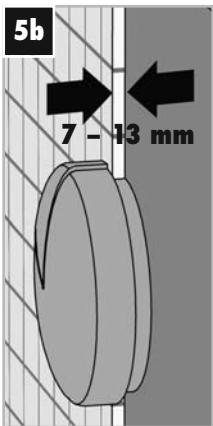
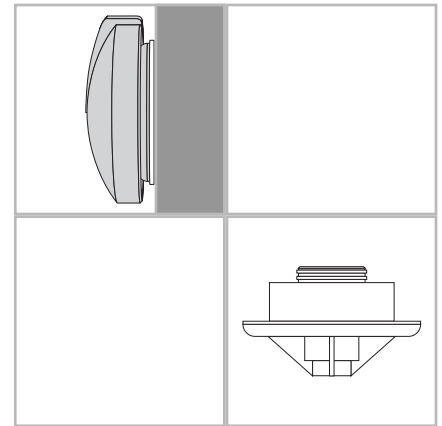
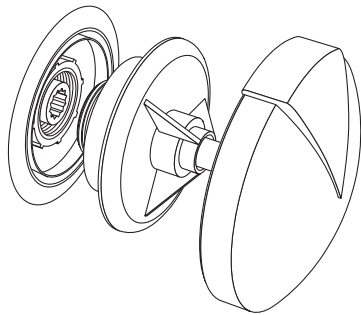
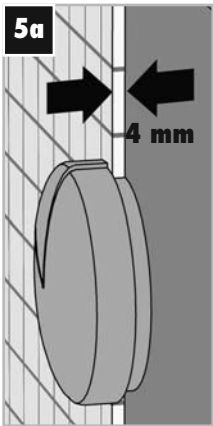
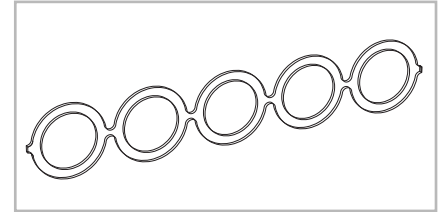

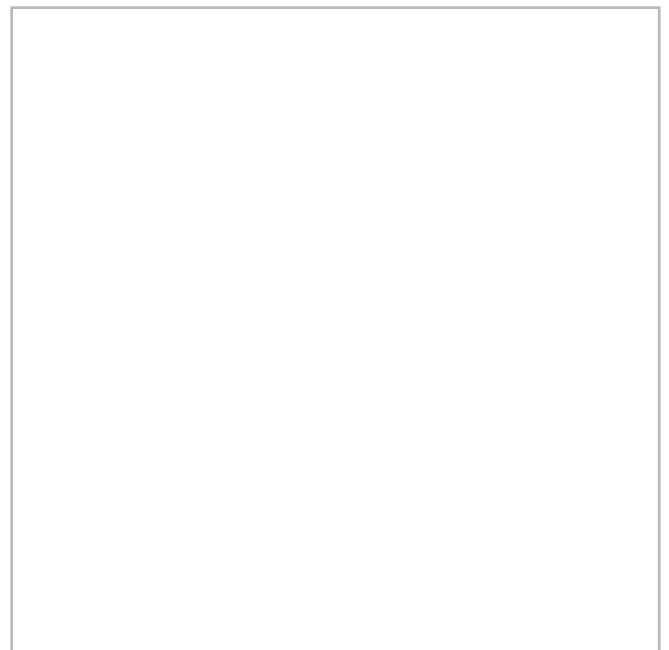
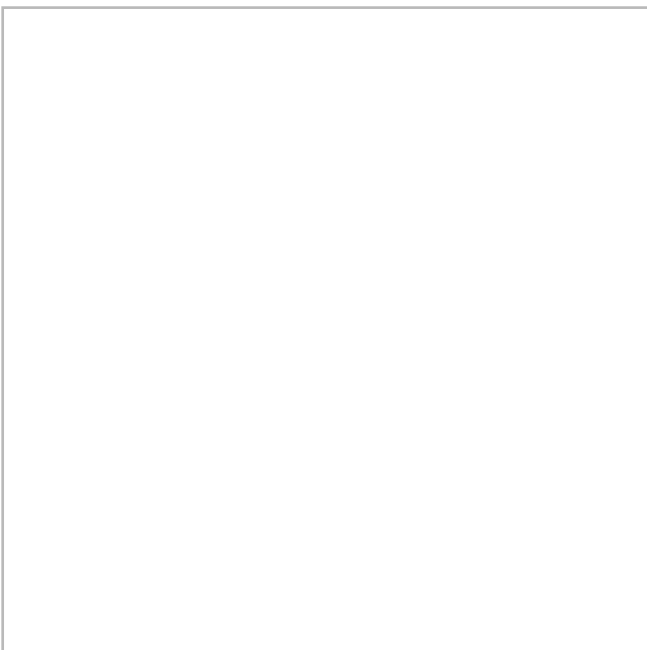
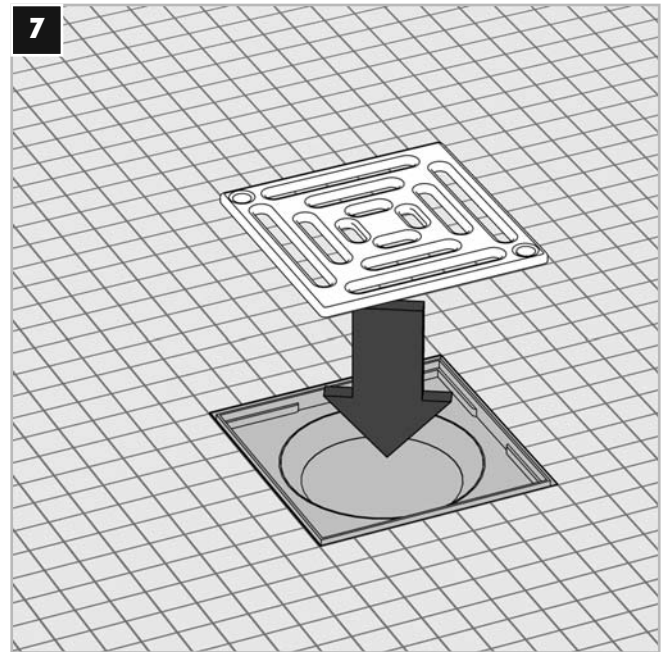
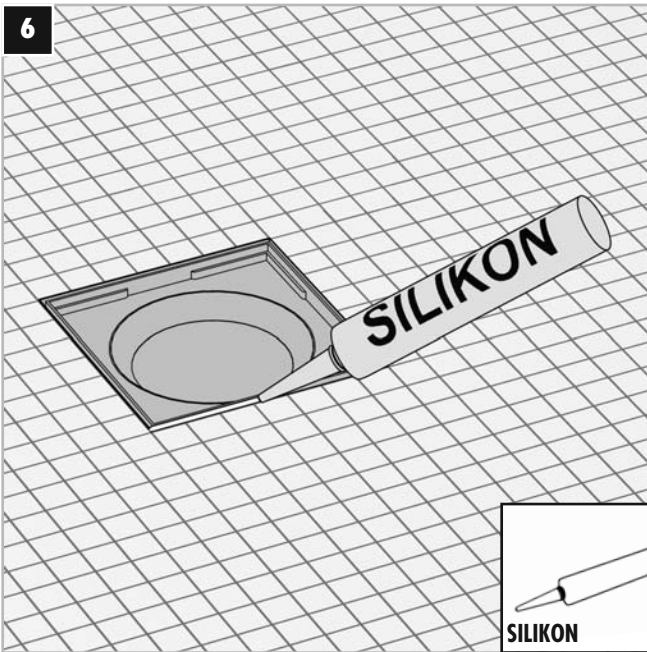

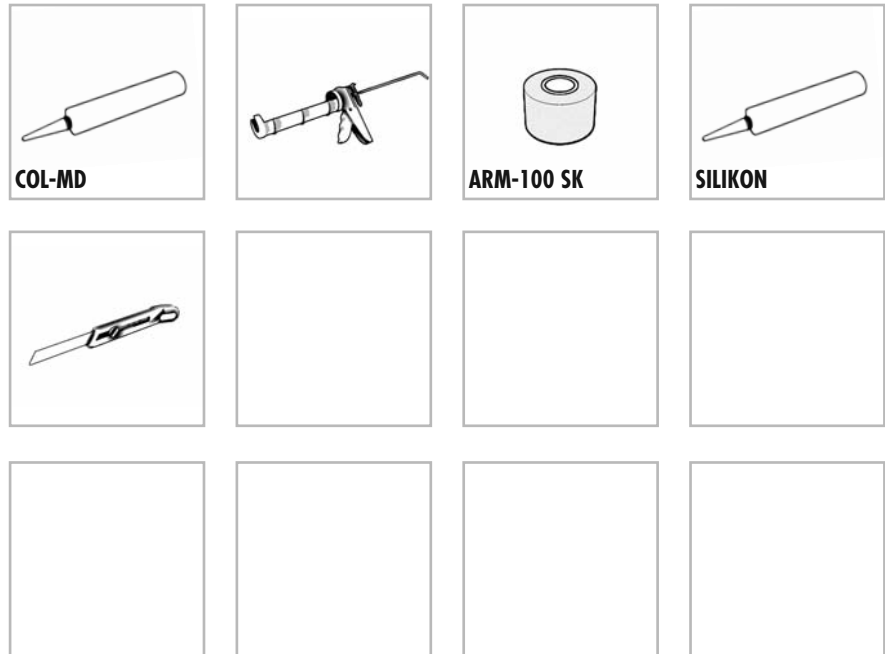
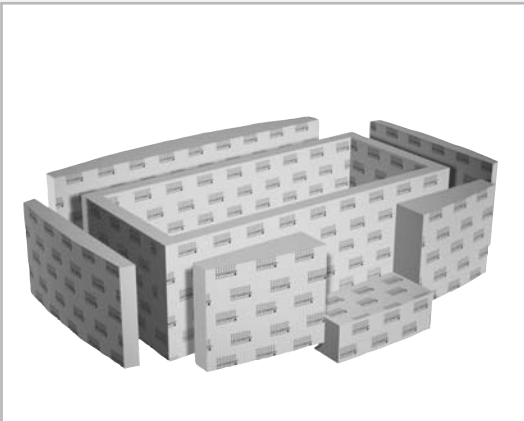

**D Bitte beachten Sie ...**

... unsere Datenblätter, die weitere technische Informationen zur Montage und Verlegung von Belagsmaterialien enthalten. Sie können diese kostenlos von unserer Homepage herunterladen. Generell empfehlen wir bei einer Verlegung von Mosaik von < 5 x 5 cm eine Verklebung und Verfugung mit Reaktionsharz.

**GB Please observe ...**

... our data sheets. These contain further technical information regarding the assembly and installation of cladding materials. You may download them free of charge from our homepage. For mosaic tiles < 5 x 5 cm we generally recommend the use of epoxy for gluing and grouting.

**F Veuillez tenir compte ...**

... de nos fiches techniques qui contiennent de plus amples informations techniques sur le montage et la pose des matériaux de revêtement. Vous pouvez les télécharger gratuitement sur notre site internet. Pour la mise en oeuvre de mosaïque d'un format < 5 x 5 nous conseillons un collage et un jointoyement à l'époxy.

**NL Gelieve op ...**

... onze gegevensbladen te letten. Deze bevatten verdere technische informatie m.b.t. plaatsing van afdekmaterialen. U kan deze kosteloos van onze internetpagina downloaden. Algemeen adviseren wij bij het kleven en het voegen van mosaik < 5 x 5 cm een epoxylijm te gebruiken.

# 3

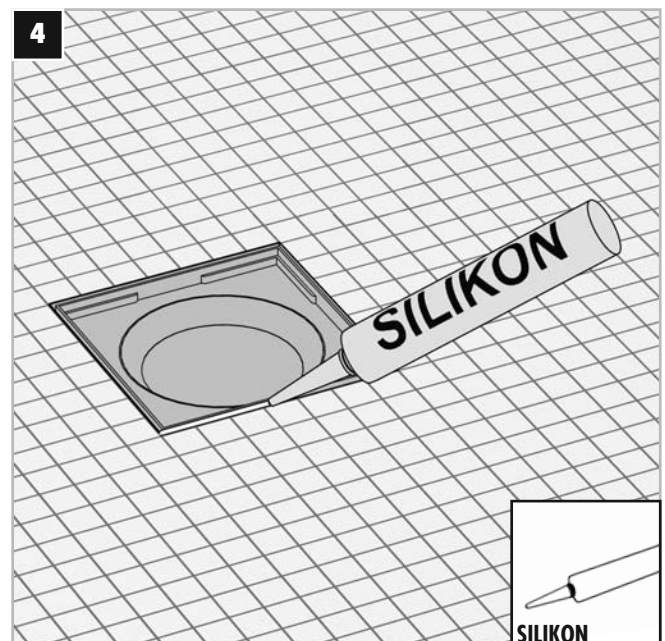
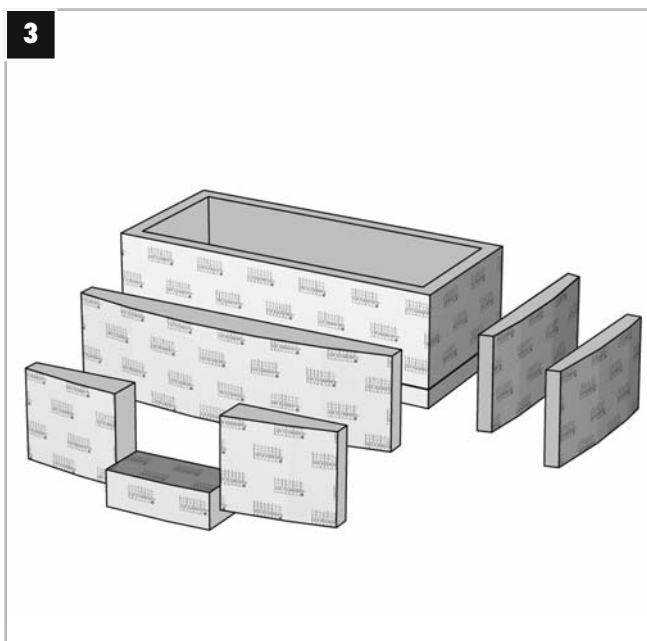
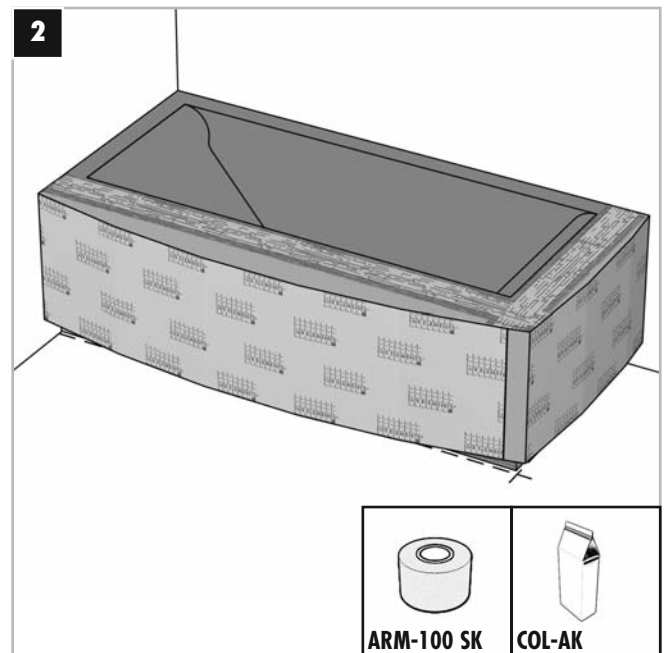
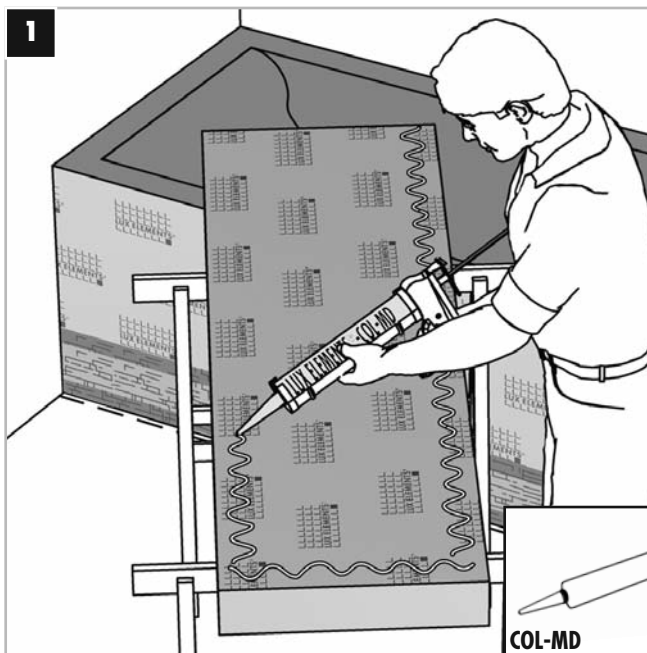

D – Die hier beispielhaft gezeigte Systematik gilt für alle Einbausituationen und Anbauteile  
 GB – The method shown here for this example is valid for all installation situations and attachment elements  
 F – L'exemple de montage donné ici est valable pour toutes les situations de montage d'éléments.  
 NL – De systematiek die hier als voorbeeld getoond wordt, geldt voor alle montagesituaties en aanbouwdelen

D – Bezüglich Farb-Set, Ablauf und Verfließung bitte die Hinweise auf Seite 15 beachten!  
 GB – Please follow the notes on page 15 regarding equipment set, floor drain and tiling!  
 F – Concernant le set de finition, le siphon de sol et le carrelage, veuillez respecter les conseils de la page 15 !  
 NL – Met betrekking tot afmontageset, afloop en betegeling gelieve de aanwijzingen op pagina 15 op te volgen!



LUX ELEMENTS®



D

LUX ELEMENTS GmbH & Co. KG  
An der Schusterinsel 7  
D - 51379 Leverkusen-Opladen

Tel. +49 (0) 21 71/ 72 12 - 0  
Fax +49 (0) 21 71/ 72 12 40

E-Mail [info@luxelements.de](mailto:info@luxelements.de)  
Web [www.luxelements.com](http://www.luxelements.com)

F

LUX ELEMENTS S.A.S.  
ZI-31, rue d'Ensisheim  
F - 68190 Ungersheim

Tél. +33 (0) 3 89 83 69 79  
Fax +33 (0) 3 89 48 83 27

E-Mail [info@luxelements.fr](mailto:info@luxelements.fr)  
Web [www.luxelements.fr](http://www.luxelements.fr)

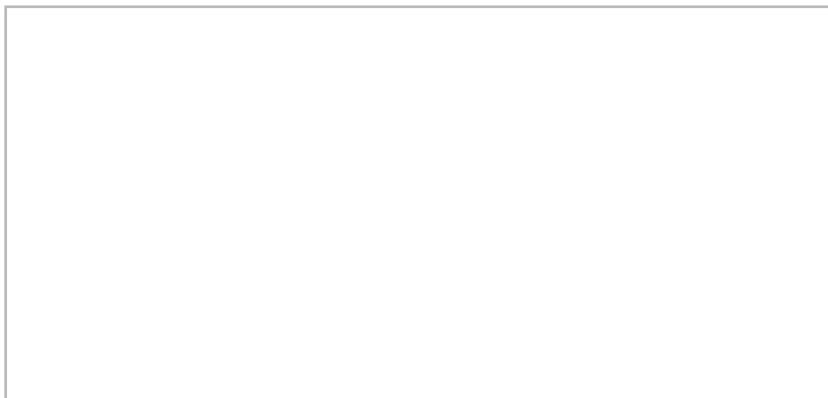

FACHVERBAND  
FLIESEN  
UND NATURSTEIN  
im Zentralverband des Deutschen Baugewerbes



Systemes  
Céramiques



VSPH  
ASCC  
ASCP



BYGGKERAMIKK  
FORENINGEN

07/2009 D – Technische Änderungen vorbehalten  
GB – Subject to technical alterations  
F – Sous réserve de modifications techniques  
NL – Onder voorbehoud van technische veranderingen