

Technische Änderungen vorbehalten.
 We reserve the right to make technical changes.
 Sous réserve de modifications techniques.
 Onder voorbehoud van technische veranderingen.

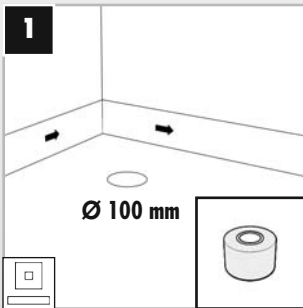

D Randdämmstreifen GB Edge insulation strip
 F Bandes périphériques NL Randisolatiestrook

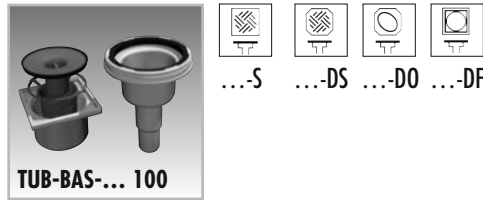
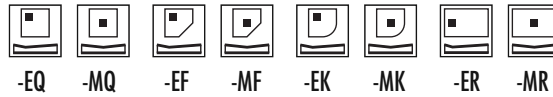
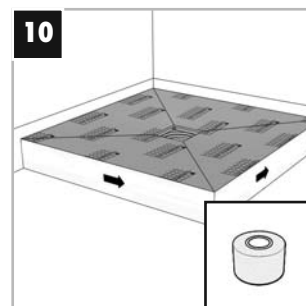
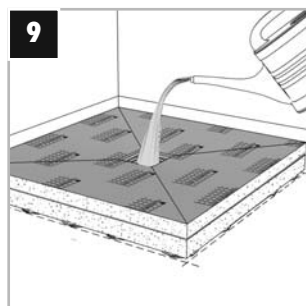
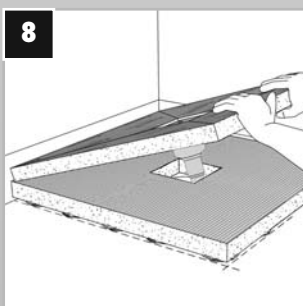
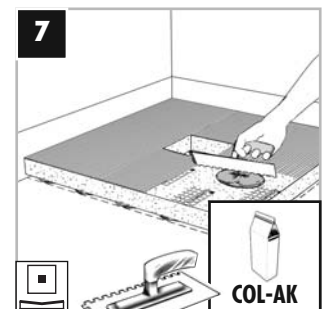
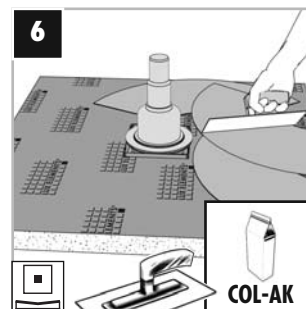
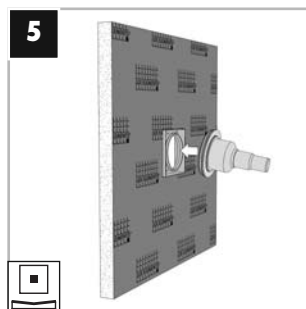
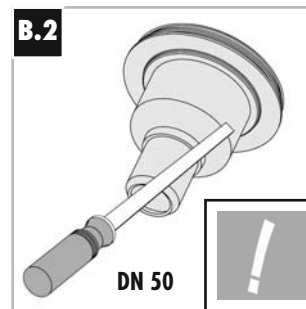
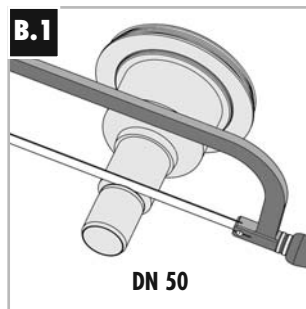
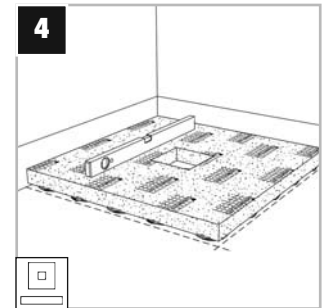
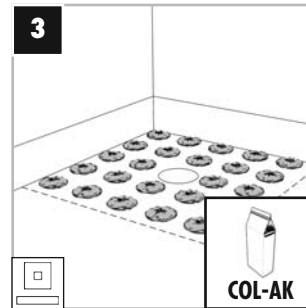
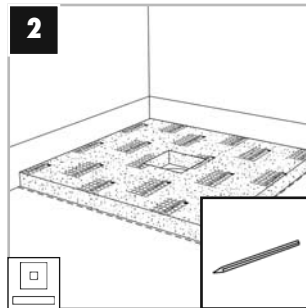

D Randdämmstreifen GB Edge insulation strip
 F Bandes périphériques NL Randisolatiestrook

D Bitte beachten Sie ...

... unsere Datenblätter, die weitere technische Informationen zur Montage und Verlegung von Belagsmaterialien enthalten. Sie können diese kostenlos von unserer Homepage herunterladen. Generell empfehlen wir bei einer Verlegung von Mosaik von < 5 x 5 cm eine Verklebung und Verfugung mit Reaktionsharz.

GB Please observe ...

... our data sheets. These contain further technical information regarding the assembly and installation of cladding materials. You may download them free of charge from our homepage. We generally advise for tiles < 5 x 5 cm to use epoxy for gluing and grouting.

F Veuillez tenir compte ...

... de nos fiches techniques qui contiennent de plus amples informations techniques sur le montage et la pose des matériaux de revêtement. Vous pouvez les télécharger gratuitement sur notre site internet. Pour la mise en oeuvre de mosaïque d un format < 5 x 5 cm nous conseillons un collage et un jointoyement à l'époxy.

NL Gelieve op ...

... onze gegevensbladen te letten. Deze bevatten verdere technische informatie m.b.t. plaatsing van afdekmaterialen. U kan deze kosteloos van onze internetpagina downloaden. Algemeen adviseren wij bij het kleven en het voegen van mosaik < 5 x 5 cm een epoxylijm te gebruiken.

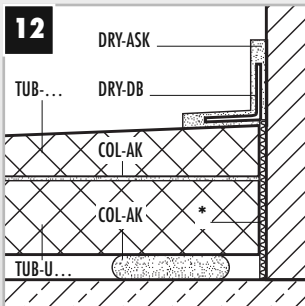

* **D** Randdämmstreifen **GB** Edge insulation strip
F Bandes périphériques **NL** Randisolatiestrook

