

Product Description

LUX ELEMENTS®-TUB shower base elements consist of a hard foam core of expanded polystyrene with special mortar coating on both sides reinforced with glass fibre fabric and factory-made sealing on the upper side with integrated and sealed floor drain support frame.

Applications

LUX ELEMENTS®-TUB-LINE shower bases are provided with ceramic covering and can be used wherever building regulations stipulate barrier-free construction e.g. in homes for the elderly, disabled person's dwellings etc. and of course wherever the comfort and aesthetics of modern building methods are desirable.

LUX ELEMENTS®-TUB shower bases fulfil the requirements for the waterproofing of buildings in conjunction with tiles and pavings according to the building rules list A, part 2 number 1.10 (version 2006/01). The range of application refers to moisture exposure class A2 for directly exposed floor areas in rooms in which service or cleaning water is frequently or continuously used, such as e.g. transitional areas in swimming pools and shower units (public and private). General Building Authority Approved Test Certificate No. P-AB/20802/05-2008 of tBU GmbH, Greven. Division preservation.



Substrate

– Firm, adequate load-bearing capacity, clean and vibration-free

Recommended use

The LUX ELEMENTS®-TUB-LINE shower bases can be shortened. In all cases, a 50 mm wide margin must remain, measured from the edge of the installation frame. We would like to point out that LUX ELEMENTS®-TUB-LINE shower bases which are not shortened all round with the same measurements then have a different external thickness due to the built-in slope, thus leading to an offset to the adjacent floor.

Please also follow the “LUX ELEMENTS®-TUB-LINE mounting instructions”

Covering materials

The LUX ELEMENTS®-TUB shower bases were specially developed for coverings with ceramic covering materials. The ceramic covering takes on the function of the load distribution layer. The loads that can be anticipated in use are to be specified by the specialist planner. The covering must be selected according to the specified load. Please note that the covering thickness (tile + adhesive) must be 11 mm in the case of the LUX ELEMENTS®-TUB-LINE COMBI shower bases.

In the case of a tile size of $\geq 20 \times 20$ mm, we recommend bonding and jointing using reaction resin.

If the size of the tiles is $\geq 50 \times 50$ mm, tile adhesive of quality grade C2 can be used for gluing and a cementitious grout material for joining. Please take note of our General Building Authority Approved Test Certificate No. P-AB/20802/05-2008 from tBU GmbH when covering our shower base elements with surface materials.

Ensure that the tiles/mosaic pieces have a sufficient breaking strength. The shower base element should not be subjected to loads greater than 0.1 N/mm².

LUX ELEMENTS®-TUB shower bases should be protected between assembly and tiling processes from damage to the sealing. Even if subjected to incorrect use, e.g. stepladders for repair work, make sure load is evenly distributed.

Technical Specifications

- Pressure strength: 0.1 N/mm²
- Including horizontal drain pot and odour trap
- Sealing water height: 22 mm
- Floor channel drain: ABS plastic
- Channel position in the case of rectangular shower bases on the short side [*]
- Channel cover: stainless steel 1.4301, load class K3 (up to max. 300 kg)
- Frame upstand: stainless steel 1.4301

LUX ELEMENTS®-TUB-LINE COMBI shower base elements

Basic form	Slope situation	Slope	Covering thickness (tile + adhesive)	Article-description	Channel length [*] in mm
rectangular	-	70 mm [**]	Shower base: 11 mm	LUX ELEMENTS®-TUB-LINE COMBI RT 900	750
				LUX ELEMENTS®-TUB-LINE COMBI RT 1200	850

[*] Other channel positions and lengths are possible on enquiry.

[**] The design of descending gradients and directions belongs to planning services. Special designs up to a maximum thickness of 65 mm are possible apart from the descending gradients stated here.

Drain performance [l/s] in accordance with DIN EN 1253		TUB-DRAW (horizontal shower drain)
LUX ELEMENTS®-TUB-LINE COMBI	Standard	0.7

■ DN 50 horizontal drain connection fitting with removable siphon trap

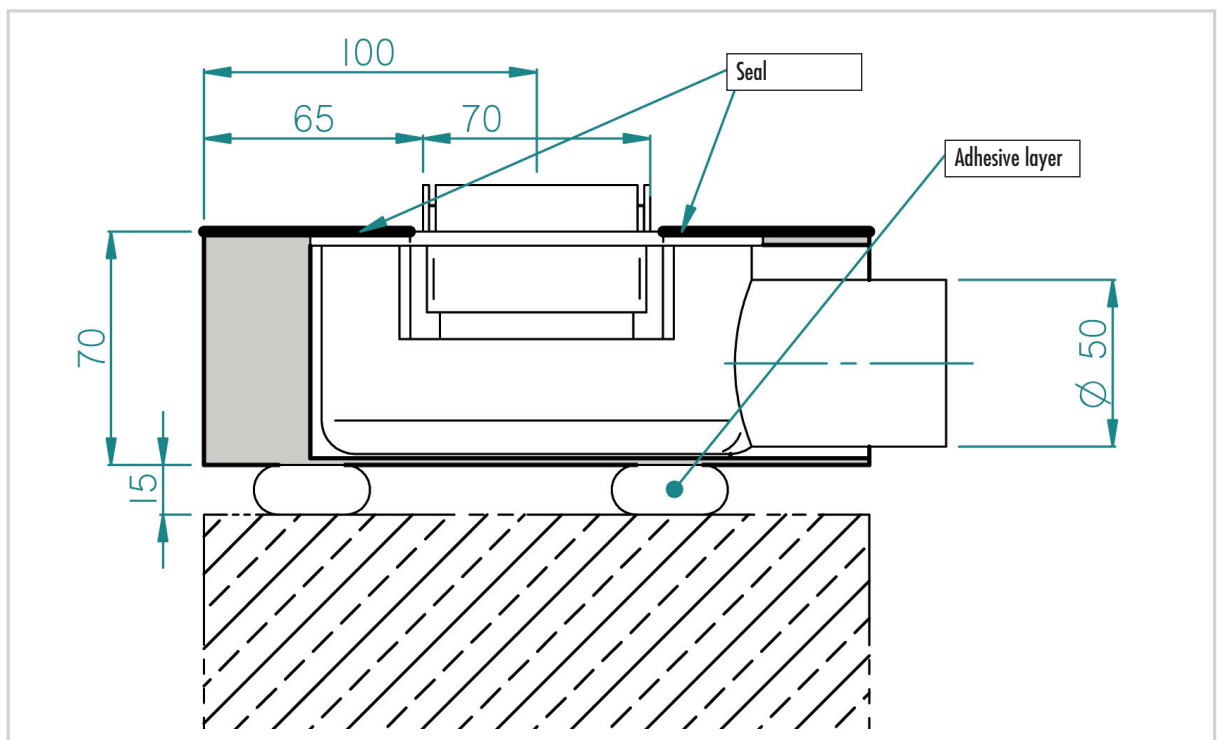

LUX ELEMENTS®-TUB-LINE COMBI shower base elements

■ In general

Please note that with flush with the floor shower bases, in the case of

- a low slope
- rough ceramics
- the lack of a shower enclosure
- unfavourable shower head placement
- high water pressure or high quantity of water (e.g. in the case of flood showers)

water can run out of the shower area or accumulate. Please refer to our planning aids and FAQ's for the planning of shower bases on our website (www.luxelements.com).

■ Accessories

LUX ELEMENTS®-TUB-BAZ BST is an adapter from DN 50 to British Standard, made of PVC.



LUX ELEMENTS®-TUB-BAZ DN 50/40 is a DN 50 to DN 40 reducer made of ABS plastic with lip seal.



LUX ELEMENTS®-TUB-BAZ HTK replaces six traditional HT bends from 0 to 87 degrees. (see data sheet LUX ELEMENTS®-TUB-BAZ HTK)

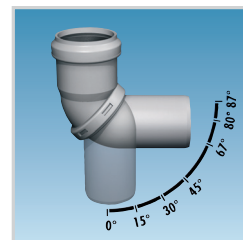

LUX ELEMENTS®-TUB-TSM, impact sound insulating mat, 1250 x 1250 x 6 mm. (see data sheet LUX ELEMENTS®-TUB-TSM)

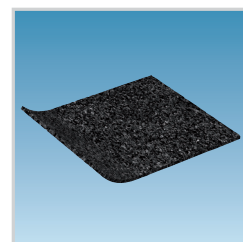

The relevant recommendations and guidelines, as well as DIN regulations, European standards and safety datasheets are to be observed. The recognised architectural and technical rules apply. We accept liability for the perfect quality of our products. Our processing recommendations are based upon trials and practical experience; they can, however, be no more than general instructions without assurance as to their quality, since we have no influence on the site conditions, on the execution of the work and the processing. With the issuing of this product datasheet previous versions cease to be valid.

LUX ELEMENTS GmbH & Co. KG

An der Schusterinsel 7
D - 51379 Leverkusen-Opladen
Tel. +49 (0) 21 71/72 12-0
Fax +49 (0) 21 71/72 12-40
E-Mail info@luxelements.de

LUX ELEMENTS S.A.S

ZI-31, rue d'Ensisheim
F - 68190 Ungersheim
Tél. +33 (0) 3 89 83 69 79
Fax +33 (0) 3 89 48 83 27
E-Mail info@luxelements.fr